



## TURBOIL-R-P14

**140 bar**



Efficiency of up to 99.5%  
at all operating speeds

Can be mounted vertically  
or horizontally, depending on model

For models with sight glasses,  
the sight glass can be replaced  
with an adapter for mounting a level switch.

Presence of a permanent magnet,  
to trap metal particles

Integrated oil reservoir

## Oil separator receivers

Maximum working pressure:  
till 140 bar at 160°C

The reliability and efficiency of TURBOIL-R-P14 oil separators are achieved thanks to a new CARLY-patented process, which simultaneously combines 2 separation chambers, namely:

### a) A static separation chamber

using several oil separation techniques:

- centrifugation by means of a helical movement generated by several spirals
- coalescence thanks to the needled material of these spirals
- sudden change in speed due to an increase in the cross-sectional area at the separator inlet
- sudden change in fluid direction

### b) A dynamic separation chamber

by coalescence and adapting to the operating regime

Maintenance-free

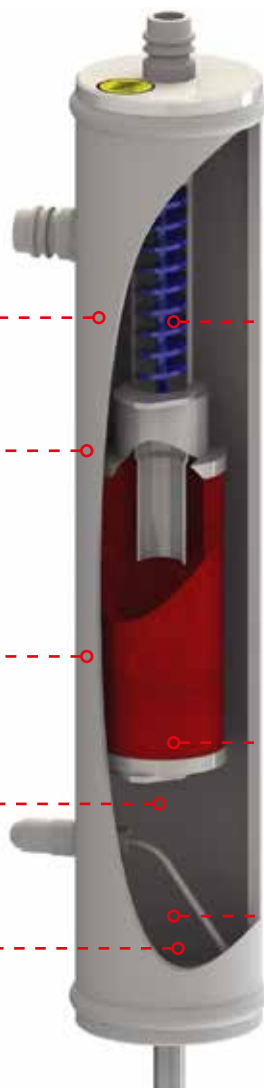

### ■ Applications

Specifically developed based on the results of many years of research, they are designed for subcritical and transcritical CO<sub>2</sub> (R744) applications up to pressures of 140 bar, and ensure:

- Separating and recovering the oil entrained in the vapour-phase refrigerant at the compressor outlet of refrigeration and air-conditioning systems.
- Limits the quantity of oil in the circuit, thus increasing heat exchanger performance.
- High-pressure oil return to compressor crankcases, helping to reduce compressor vibrations and discharge gas noise.
- By choosing TURBOIL-R-P14 oil separator tanks, you can avoid having to install a separate oil receiver.
- Recommended for very low-temperature applications.

### ■ Functional features

- Products are classified in CE categories using the table in PED 2014/68/EU, corresponding to selection by volume.
- Hermetically sealed carbon steel outer casing, with 160°C polyurethane paint for high corrosion resistance.
- Recognized efficiency with all EN378 group 2 fluids.
- Oil reserve function provided by built-in reservoir.
- High-pressure oil outlet via 1/4" or 3/8" SAE connection, depending on model.



#### Customization available on request:

- Compatible with group 1 fluids
- Customized oil receiver volume



# TURBOIL-R-P14

## 140 bar

# Oil separator receivers

### ■ Warning

Before selecting or installing any component, please refer to chapter 0 of the CARLY technical catalog - **WARNING**.

### ■ General assembly precautions

The installation of a component on a refrigeration system by a skilled professional requires some precautions:

- Some are specific to each components and in this case, they are specified in the **RECOMMANDATIONS SPECIFIC** part defined hereafter;
- Others are general to all CARLY components, they are presented in the chapter 115 - **GENERAL ASSEMBLY PRECAUTIONS**.

### ■ Recommendations specific to oil separator receivers TURBOIL-R-P14

- The recommendations are identical to those for TURBOIL® oil separators (see chapter 41).
- Caution: discharge temperatures can be very high. We recommend that you take all necessary precautions..
- Given the high oil pressure at the TURBOIL-R-P14 outlet, the use of LEVOIL mechanical oil level regulators is not possible, so we recommend the use of electronic oil level regulators.
- For multi-compressor installations, CARLY recommends the use of one TURBOIL-R-P14 oil separator per compressor.
- When starting up a new installation, fill the TURBOIL-R-P14 tank section with the same oil used in the compressors.
- During the first two days of operation, carefully monitor the oil level in the separator tanks. For oil pre-loading, refer to the selection table.)
- If the system has already been running, oil must be added with great care. After the first day's operation, the oil reintegrated into the system should be sufficient to fill the TURBOIL-R® reservoir to the top sight glass. If the oil level has not reached the upper sight glass, the necessary quantity of oil must be topped up. On the other hand, if the oil level exceeds the upper sight glass, it is imperative to drain the excess; this operation is possible via the TURBOIL-R® lower valve.
- Always use the same oil as the compressor(s).
- Since oil separation efficiency is never 100%, especially at variable operating speeds, the installation of an oil separator does not mean that oil traps and slopes in the direction of the fluid should be avoided when designing and building the system's piping. A check valve can be installed on the oil separator's gas outlet piping, to prevent any backflow of liquid refrigerant from the condenser.
- Ensure that the connection diameter of the TURBOIL-R-P14 oil separator is equal to the diameter of the compressor discharge line or discharge manifold.



## TURBOIL-R-P14

**140 bar**

## Oil separator receivers

### ■ Selection table

The person responsible for sizing a product must take into account the conditions under which it will be used (temperature - pressure - fluid - oil - external environment). The values given in the selection tables in the CARLY catalog correspond to precise test conditions.

We advise you to convert your operating data into data corresponding to the CARLY selection table in order to enable you to dimension rigorously and correctly.

CARLY references	Connections To solder ODF inch / mm	Working conditions	Refrigerating capacity (kW)						Mass flow (kg/s)					
			+ 10 °C	0 °C	-10 °C	-20 °C	-30 °C	-40 °C	+ 10 °C	0 °C	-10 °C	-20 °C	-30 °C	-40 °C
TURBOIL-R-P14 103 S	3/8 / 10	75bar / 30°C	21,0	18,1	15,3	12,4	9,6	6,8	0,149	0,129	0,108	0,088	0,068	0,048
		90bar / 35°C	18,4	15,7	13,0	10,3	7,6	4,9	0,138	0,118	0,097	0,077	0,057	0,037
		100bar / 40°C	15,8	13,3	10,7	8,1	5,6	3,1	0,132	0,111	0,089	0,068	0,047	0,026
		120bar / 50°C	13,2	10,9	8,4	5,9	3,6	1,2	0,137	0,113	0,087	0,061	0,037	0,013
TURBOIL-R-P14 205 S	5/8 / 16	75bar / 30°C	69,8	60,4	50,8	41,3	32,0	22,6	0,496	0,429	0,361	0,294	0,228	0,161
		90bar / 35°C	61,1	52,3	43,2	34,1	25,4	16,4	0,458	0,392	0,324	0,256	0,190	0,123
		100bar / 40°C	52,5	44,2	35,6	26,9	18,7	10,2	0,439	0,370	0,298	0,225	0,156	0,086
		120bar / 50°C	43,8	36,2	27,9	19,7	12,0	4,0	0,456	0,377	0,291	0,205	0,125	0,042
TURBOIL-R-P14 207 S	7/8 / 22	75bar / 30°C	119,4	103,3	86,9	70,7	54,8	38,7	0,848	0,734	0,617	0,502	0,389	0,275
		90bar / 35°C	104,6	89,5	73,9	58,4	43,4	28,1	0,784	0,671	0,554	0,438	0,325	0,211
		100bar / 40°C	89,7	75,7	60,8	46,0	31,9	17,5	0,752	0,634	0,510	0,385	0,267	0,146
		120bar / 50°C	74,9	61,9	47,8	33,6	20,5	6,9	0,780	0,644	0,498	0,350	0,213	0,072
TURBOIL-R-P14 309 S	1 1/8	75bar / 30°C	185,5	160,6	135,1	109,9	85,2	60,2	1,318	1,141	0,959	0,781	0,605	0,428
		90bar / 35°C	162,5	139,1	114,8	90,7	67,4	43,7	1,219	1,043	0,861	0,680	0,506	0,328
		100bar / 40°C	139,5	117,6	94,6	71,5	49,6	27,2	1,168	0,985	0,792	0,599	0,416	0,228
		120bar / 50°C	116,5	96,1	74,3	52,3	31,8	10,7	1,213	1,001	0,774	0,544	0,332	0,111
TURBOIL-R-P14 411 S	1 3/8 / 35	75bar / 30°C	252,4	218,4	183,7	149,6	115,9	81,9	1,793	1,552	1,305	1,062	0,823	0,582
		90bar / 35°C	221,1	189,2	156,2	123,4	91,7	59,4	1,658	1,419	1,171	0,926	0,688	0,446
		100bar / 40°C	189,8	160,0	128,6	97,2	67,5	37,0	1,589	1,340	1,077	0,814	0,565	0,310
		120bar / 50°C	158,4	130,8	101,1	71,1	43,3	14,6	1,650	1,362	1,052	0,740	0,451	0,152
TURBOIL-R-P14 813 S	1 5/8	75bar / 30°C	466,9	404,1	339,9	276,7	214,4	151,5	3,317	2,870	2,414	1,966	1,523	1,076
		90bar / 35°C	409,0	350,0	288,9	228,3	169,7	110,0	3,067	2,625	2,167	1,712	1,273	0,825
		100bar / 40°C	351,1	296,0	237,9	179,9	124,9	68,4	2,940	2,479	1,993	1,507	1,046	0,573
		120bar / 50°C	293,1	241,9	187,0	131,5	80,1	26,9	3,053	2,519	1,947	1,369	0,835	0,280



# TURBOIL-R-P14

**140 bar**

## Oil separator receivers

### ■ Technical features

CARLY references	Connections To solder ODF inch	Connections To solder ODF mm	Connections types	Drawing No	Ø1	Ø2	Ø3	L	E1	E2	E3	E4	E5	E6	E7	E8
TURBOIL-R-P14 103 S/MMS	3/8	10	4	1	60,3	64	M10	340	59	54	255	54	-	-	-	-
TURBOIL-R-P14 205 S/MMS	5/8	16	5	2	88,9	92	M10	595	64	69	494	80	87	64	-	-
TURBOIL-R-P14 207 S/MMS	7/8	22	5	2	114,3	118	M12	662	65	81	549	101	99	65	-	-
TURBOIL-R-P14 309 S	1"1/8	28	6	3	141,3	146	M12	755	68	95	623	131	113	68	280	-
TURBOIL-R-P14 411 S/MMS	1"3/8	35	6	4	168,3	172	-	898	139	121	559	140	135	139	269	679

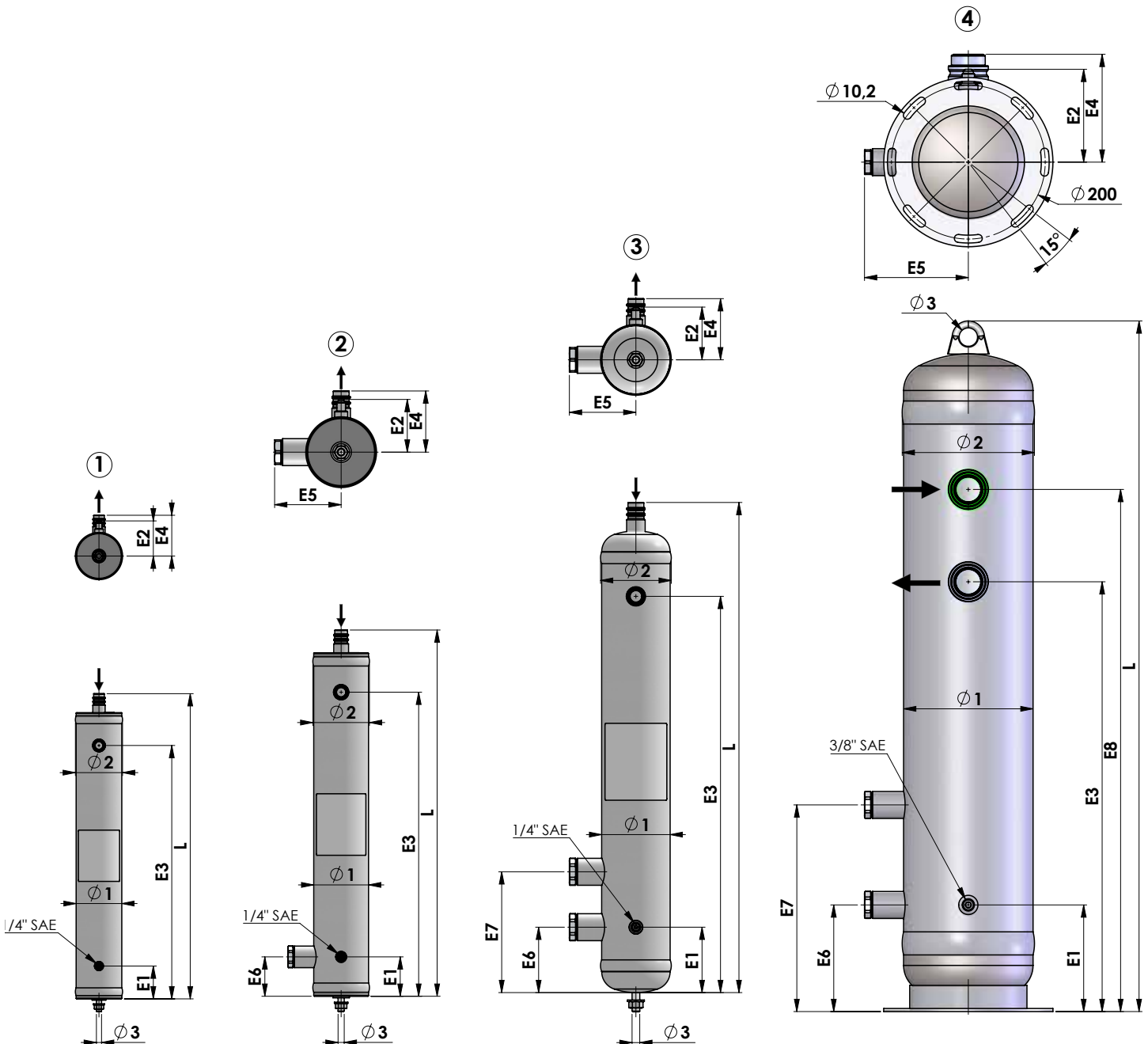



# TURBOIL-R-P14

**140 bar**

## Oil separator receivers

### ■ Technical features

CARLY references	Drawing No	Volume total	Volume of the receiver	Volume <sup>(3)</sup>		Maximal working pressure	Working pressure <sup>(1)</sup>	Maximal working temperature	Minimal working temperature	Working temperature <sup>(1)</sup>	CE Category <sup>(2)</sup>
		V L	VR L	V1 L	V2 L	PS bar	PS BT bar	TS maxi °C	TS mini °C	TS BT °C	
TURBOIL-R-P14 103 S/MMS	1	0,62	0,20	-	-	140	15	160	-40	-30	Art4§3
TURBOIL-R-P14 205 S/MMS	2	2,50	0,75	0,20	-	140	15	160	-40	-30	II
TURBOIL-R-P14 207 S/MMS	2	4,30	1,45	0,40	-	140	15	160	-40	-30	II
TURBOIL-R-P14 309 S	3	7,60	3,00	0,50	3,00	140	15	100	-40	-30	III
TURBOIL-R-P14 411 S/MMS	4	13,0	3,80	1,60	3,80	140	15	160	-40	-30	III

<sup>(1)</sup> The working pressure is limited to the PS BT value when working temperature is lower than or equal to TS BT value.

<sup>(2)</sup> Classification by volume, according to PED 2014/68/EU (refer to chapter 0).

<sup>(3)</sup> Volume corresponding to sight glasses' level V1 and V2.

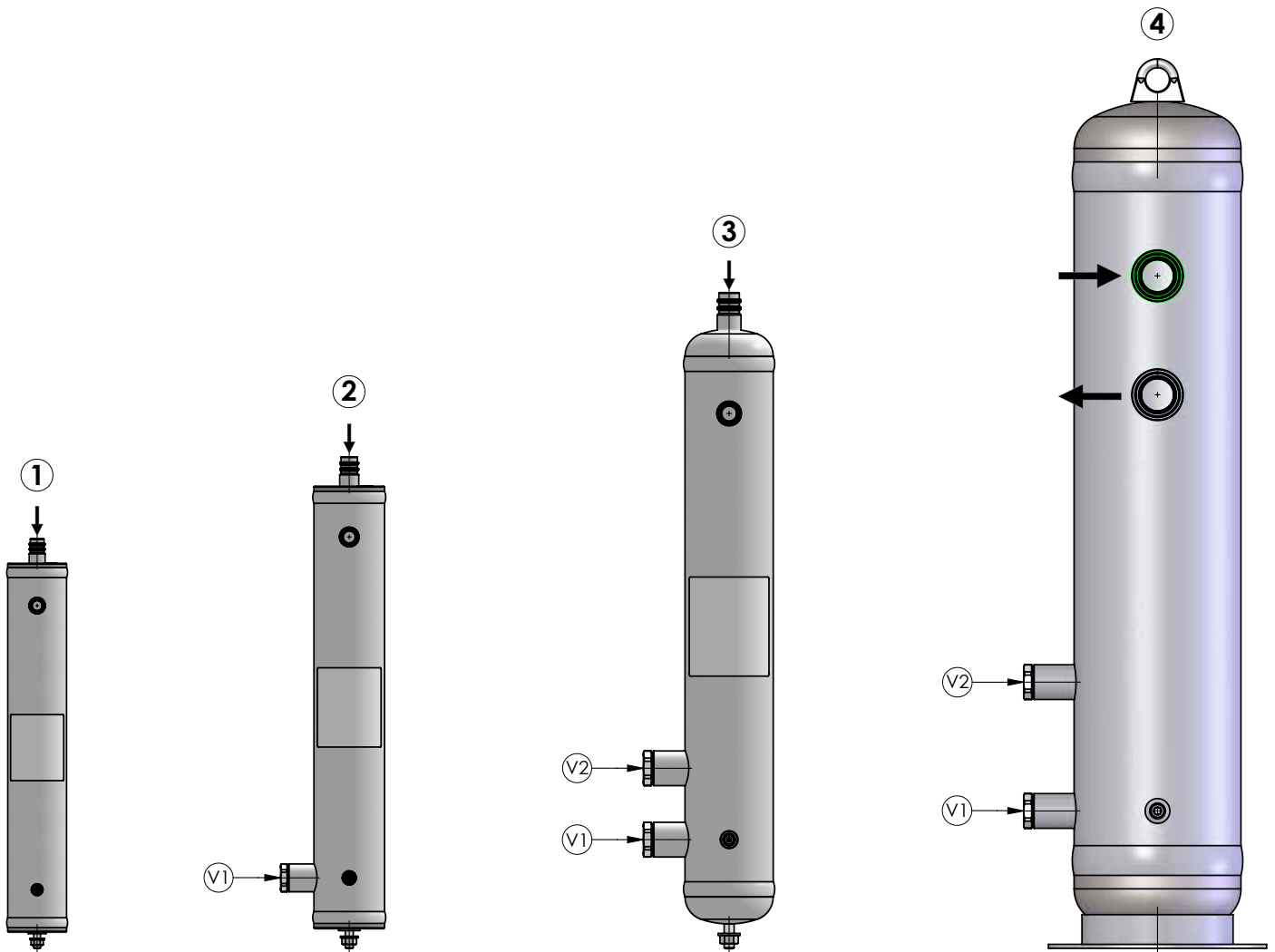



# TURBOIL-R-P14

## 140 bar

## Oil separator receivers

### ■ Spare parts and options

CARLY reference	Part number	Description	Quantity
CY 15011160	1	Glass without hygroscopic crown (flat aluminum gasket included)	1
CY 15511160	2	Aluminum flat gasket	1
CY 17400160	3	1/2" NPT level sensor adapter (incl. aluminum flat gasket)	1

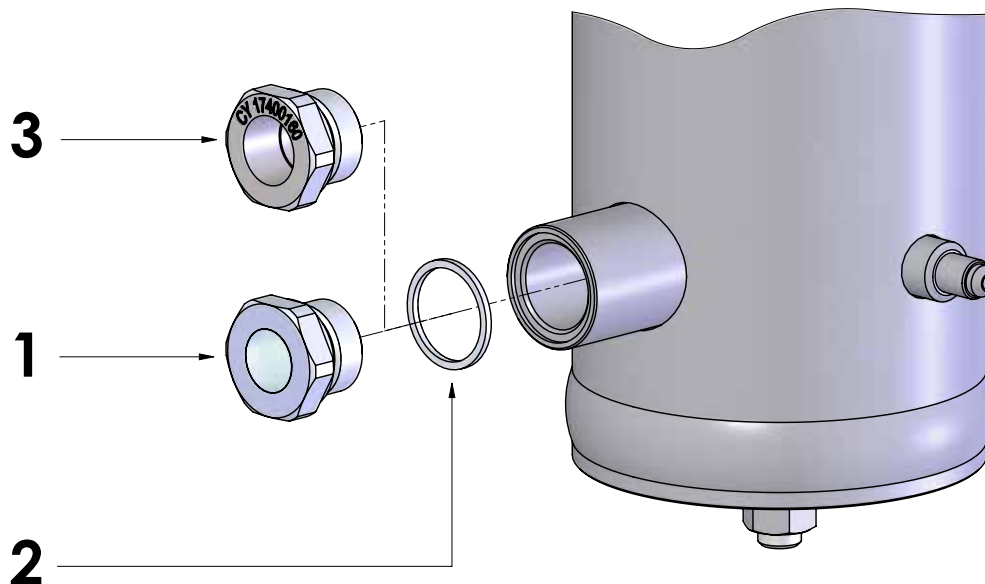

### ■ Weights and Packaging

CARLY reference	Unit weight kg		Packaging Number of pieces
	With packaging	Without packaging	
TURBOIL-R-P14 103 S/MMS	3,00	2,60	1
TURBOIL-R-P14 205 S/MMS	10,00	9,40	1
TURBOIL-R-P14 207 S/MMS	18,00	16,80	1
TURBOIL-R-P14 309 S	30,30	27,90	1
TURBOIL-R-P14 411 S/MMS	49,00	47,00	1