



Oil filters

→ HCYF-P6 / 64 bar (928 psig)

■ Applications

- Oil filtering on the oil return line to the compressor sumps of refrigerating and air conditioning installations, running in high working pressures.
- These filters are required for the good operation of oil level regulators and compressors. It protect them from any contaminants that could damage them (metallic chips, filings, oxides, sludge, etc...).



64 bar

CO₂ SUBCRITICAL

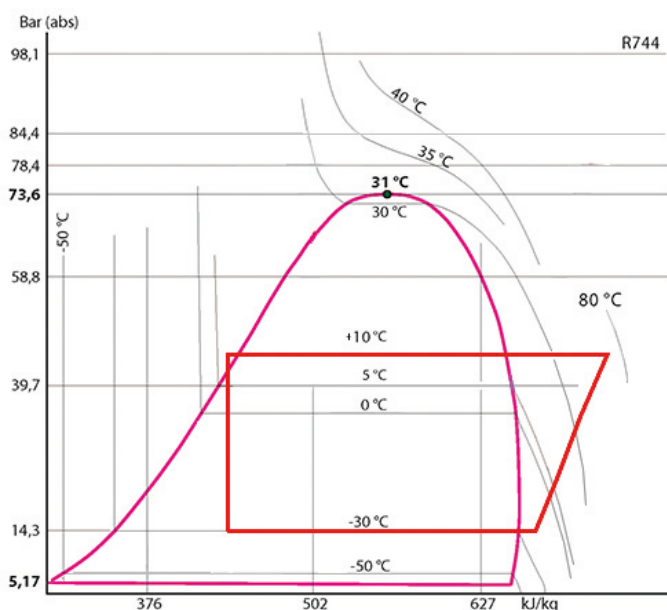

■ Functional features

- Products are compatible with HFC, CO₂, as well as with their associated oils and additives. Products are designed for use of non-hazardous refrigerants from group 2 of PED 2014/68/EU.
- Product classification in CE categories is performed using the PED 2014/68/EU table, corresponding to a volume-based selection.
- Hermetically sealed outer steel enclosure with paint to ensure a high resistance to corrosion.
- Filtrating core made of stainless steel mesh cloth.
- Filtering efficient at 5 microns.
- Several types of connections are possible on standard products:
 - To be screwed type SAE
 - To be brazed for tubes in inches (S)
 - To be brazed for tubes in millimetres (MMS).



Possible customization on demand :

- Specific connections (O-RING, ORFS,...).
- Stainless steel casings and unions (resistance to corrosion and at low temperatures).
- Lower filtration threshold.
- Filtering surface of the core, more or less important according to the specificities of the machine.

■ CARLY advantages

- Maximum working pressure: up to 64 bar with CO₂ in subcritical compression systems.
- Very large filtering surface areas for very low pressure drop.
- Presence of a permanent magnet located at the inlet of the filter, ensuring the immediate "trapping" of all steel particles.
- Very large range of filters: 6 different models.
- Connections to solder are made of copper-plated steel and allow to use brazing alloys with a low silver percentage; their resistance to pressure is much higher than the full copper connections.



Oil filters

→ HCYF-P6 / 64 bar (928 psig)

■ Warning

Before selecting or installing any component, please refer to the chapter 0 of CARLY technical catalogue - **WARNING**.

■ General assembly precautions

The installation of a component in a refrigeration system by a skilled professional, requires some precautions:

- Some are specific to each component,
- Other are general to all CARLY components,

and in this case, they are specified in the **RECOMMENDATIONS SPECIFIC** part defined hereafter ;

they are presented in the chapter 115 of CARLY technical catalogue – **GENERAL ASSEMBLY PRECAUTIONS**.

■ Recommendations specific to the oil filters HCYF-P6

- The oil filters are to be mounted on the oil return line, between the oil separator and the oil level regulator, as close as possible to the latter.
- The direction of oil flow, indicated by an arrow on the filter tag and by an “IN” sticker next to the inlet connection, must imperatively be respected.
- The degree of clogging of the filters must be regularly checked, ensuring that the oil return is correct in the crankcases of compressors; oil filters must be imperatively replaced at the first sign of clogging.
- It is highly recommended to install downstream oil filter an oil sight glass in order to visually check the presence and the condition of the oil.
- HCYF-P6 oil filter only ensures mechanical filtering of solid contaminants.
- Make sure that the piping can support without deformation the weight of the oil filter; otherwise, plan the attachment of the oil filter with a clamp on a stable part of the installation.



Oil filters

→ HCYF-P6 / 64 bar (928 psig)

■ Special precautions for components used with CO₂ in subcritical and transcritical systems

- The maximal working pressure and the power variations of the installation must be taken into account as of its design, in order to select all the components consequently.
- The pressure of the circuit during the stop phases must also be taken into account, because it can be very high, due to the pressure equalization according to the ambient temperature; several solutions exist to limit and control this pressure when the installation is stopped.
 - Design of the installation allowing to resist to this pressure.
 - Implementation of a « buffer » volume of storage or expansion (receiver).
 - Installation of a secondary circuit with valve or solenoid valve, allowing the fluid transfer to the coldest point, or the less high in pressure of the installation.
 - Implementation of a small separate refrigeration unit, to maintain the liquid temperature at a pressure lower than the maximal working pressure ; it is so far the most effective technical solution, but with a major drawback, which is the power failure (safety unit to be considered, or backup power supply).
- The hot gas defrost, frequently used with CO₂ for low temperatures applications, generates also high pressures (to take in consideration)
- The implementation on the liquid line of a filter drier **DCY-P6**, or a filter drier shell **BCY-P6** equipped with drying cores **CCY 48 HP** or **PLATINIUM 48**, is highly recommended. Serious problems can occur in the presence of moisture, such as expansion valve blocking and formation of dry ice and even carbonic acid. To avoid this, it is imperative to limit the circuit openings in order to avoid air introduction, causing the condensation in the pipes, and to proceed to a high evacuation of the installation, before any commissioning or restarting.
- For an operation with CO₂ at low temperature, provide thermal insulation on the components which can be covered by frost.
- There is no incompatibility between CO₂ and the main metallic materials commonly used in refrigeration systems (steel, copper, brass...)
- On the other hand, there is a real compatibility issue between CO₂ and polymers. For example, swelling phenomena and internal explosion of the seal are possible. Carly oil filters HCYF-P6 do not have polymer gaskets directly in contact with CO₂.



Oil filters

→ HCYF-P6 / 64 bar (928 psig)

■ Technical features

CARLY references	Connections To screw SAE inch	Connections To solder ODF inch	CARLY references	Connections To solder ODF mm	Connections types (1)	Drawing Nb	Filtering surface cm ²	Dimensions mm		
								Ø1	Ø2	L
HCYF-P6 52	1/4				1	1	70	50	55	119
HCYF-P6 53	3/8				1	1	70	50	55	125
HCYF-P6 53 S		3/8	HCYF-P6 53 MMS	10	2	2	70	50	55	112
HCYF-P6 83	3/8				1	1	121	89	96	142
HCYF-P6 84	1/2				1	1	121	89	96	146

(1) Chapter "Connection features and drawings" (refer to chapter 114 of CARLY technical catalogue).

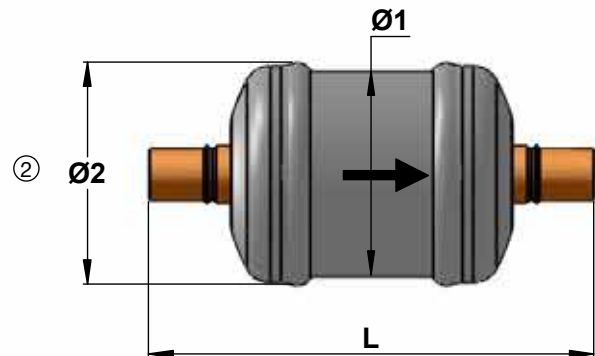
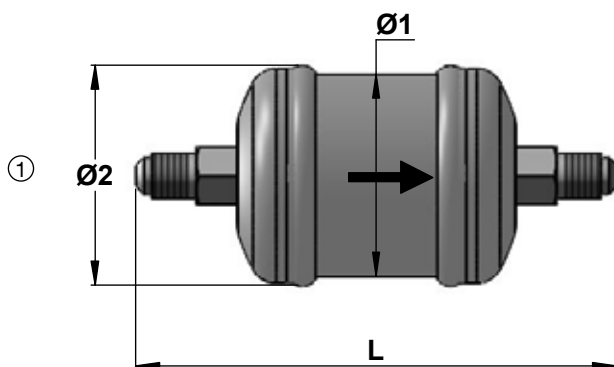

CARLY references	Volume V L	Maximal working pressure PS bar	Working pressure (1)		Maximal working temperature TS maxi °C	Minimal working temperature TS mini °C	Working temperature (1)		CE Category (2)
			PS BT bar	TS BT °C					
HCYF-P6 52	0,15	64	15	120	-40	-30	Art4§3		
HCYF-P6 53	0,15	64	15	120	-40	-30	Art4§3		
HCYF-P6 53 S	HCYF-P6 53 MMS	0,15	64	15	120	-40	-30	Art4§3	
HCYF-P6 83	0,50	64	15	120	-40	-30	Art4§3		
HCYF-P6 84	0,50	64	15	120	-40	-30	Art4§3		

(1) The working pressure is limited to the PS BT value when working temperature is lower than or equal to TS BT value.

(2) Classification by volume, according to PED 2014/68/EU (refer to chapter 0 of CARLY technical catalogue).



Oil filters

→ HCYF-P6 / 64 bar (928 psig)

■ Weights and packaging

CARLY references	Unit weight kg		Packaging number of pieces
	With packaging	Without packaging	
HCYF-P6 52	0,31	0,28	1
HCYF-P6 53	0,31	0,28	1
HCYF-P6 53 S & MMS	0,31	0,28	1
HCYF-P6 83	0,78	0,75	1
HCYF-P6 84	0,83	0,80	1