



Oil filters

→ HCYF-P14 / 140 bar (2030 psig)

■ Applications

- Oil filtering on the oil return line to the compressor sumps of refrigerating and air conditioning installations, running with high working pressures, with CO₂ in transcritical compression systems.
- These filters are required for the good operation of oil level regulators and compressors. They protect them from any contaminants that could damage them (metallic chips, filings, oxides, sludge, etc...).



140 bar



TRANSCRITICAL

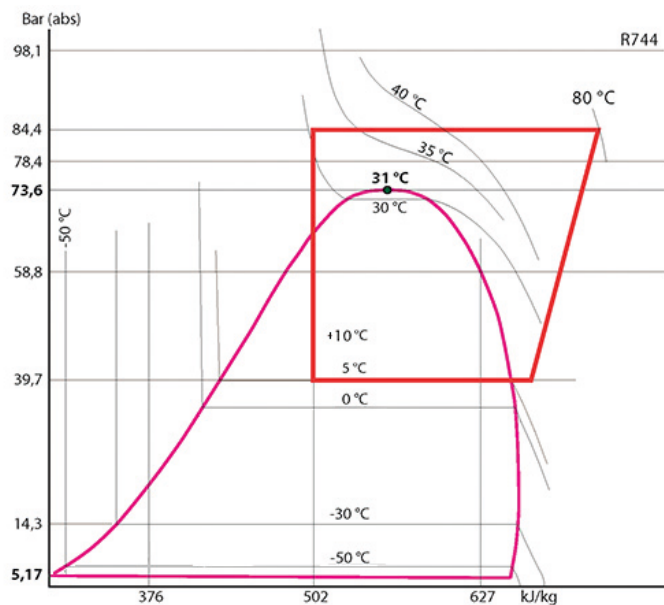

■ Functional features

- Products are compatible with CO₂, as well as with its associated oils and additives. Products are designed for use of non-hazardous refrigerants from group 2 of PED 2014/68/EU.
- Product classification in CE categories is performed using the PED 2014/68/EU table, corresponding to a volume-based selection.
- Hermetically sealed outer steel enclosure with paint to ensure a high resistance to corrosion.
- Filtrating core made of stainless steel mesh cloth.
- Filtering efficient at 5 microns.
- Connections on standard products: screwed type SAE and ODF to solder.



Possible customization on demand :

- Specific connections (O-RING, ORFS,...).
- Stainless steel casings and unions (resistance to corrosion and at low temperatures).
- Lower filtration threshold.
- Filtering surface of the core, more or less important according to the specificities of the machine.

■ CARLY advantages

- Maximum working pressure: up to 140 bar with CO₂ in transcritical compression systems.
- Very large filtering surface areas for very low pressure drop.
- Automatic bypass of the internal filter when it is too dirty and when the pressure drop generated exceeds 3 bar; this particularity ensures the continuity of compressor lubrication, even if filter maintenance is late.



Oil filters

→ HCYF-P14 / 140 bar (2030 psig)

■ Warning

Before selecting or installing any component, please refer to the chapter 0 of CARLY technical catalogue - **WARNING**.

■ General assembly precautions

The installation of a component in a refrigeration system by a skilled professional, requires some precautions:

- Some are specific to each component,
- Other are general to all CARLY components,

and in this case, they are specified in the **RECOMMENDATIONS SPECIFIC** part defined hereafter ;

they are presented in the chapter 115 of CARLY technical catalogue – **GENERAL ASSEMBLY PRECAUTIONS**.

■ Recommendations specific to the oil filters HCYF-P14

- The oil filters are to be mounted on the oil return line, between the oil separator and the oil level regulator, as close as possible to the latter.
- The direction of oil flow, indicated by an arrow on the filter tag and by an “IN” sticker next to the inlet connection, must imperatively be respected.
- The degree of clogging of the filters must be regularly checked, ensuring that the oil return is correct in the crankcases of compressors; oil filters must be imperatively replaced at the first sign of clogging.
- It is highly recommended to install downstream oil filter an oil sight glass in order to visually check the presence and the condition of the oil.
- HCYF-P14 oil filter only ensures mechanical filtering of solid contaminants.
- Make sure that the piping can support without deformation the weight of the oil filter; otherwise, plan the attachment of the oil filter with a clamp on a stable part of the installation.



Oil filters

→ HCYF-P14 / 140 bar (2030 psig)

■ Special precautions for components used with CO₂ in subcritical and transcritical systems

- The maximal working pressure and the power variations of the installation must be taken into account as of its design, in order to select all the components consequently.
- The pressure of the circuit during the stop phases must also be taken into account, because it can be very high, due to the pressure equalization according to the ambient temperature; several solutions exist to limit and control this pressure when the installation is stopped.
 - Design of the installation allowing to resist to this pressure.
 - Implementation of a « buffer » volume of storage or expansion (receiver).
 - Installation of a secondary circuit with valve or solenoid valve, allowing the fluid transfer to the coldest point, or the less high in pressure of the installation.
 - Implementation of a small separate refrigeration unit, to maintain the liquid temperature at a pressure lower than the maximal working pressure ; it is so far the most effective technical solution, but with a major drawback, which is the power failure (safety unit to be considered, or backup power supply).
- The implementation on the liquid line of a filter drier **DCY-P14**, or a filter drier shell **BCY-P14** equipped with drying cores **CCY 48 HP** or **PLATINIUM 48**, is highly recommended. Serious problems can occur in the presence of moisture, such as expansion valve blocking and formation of dry ice and even carbonic acid. To avoid this, it is imperative to limit the circuit openings in order to avoid air introduction, causing the condensation in the pipes, and to proceed to a high evacuation of the installation, before any commissioning or restarting.
- For an operation with CO₂ at low temperature, provide thermal insulation on the components which can be covered by frost.
- There is no incompatibility between CO₂ and the main metallic materials commonly used in refrigeration systems (steel, copper, brass...)
- On the other hand, there is a real compatibility issue between CO₂ and polymers. For example, swelling phenomena and internal explosion of the seal are possible. Carly oil filters HCYF-P14 do not have polymer gaskets directly in contact with CO₂.



Oil filters

→ HCYF-P14 / 140 bar (2030 psig)

■ Technical features

CARLY references	Connections To screw SAE inch	Connections To solder ODF inch	Connections To solder ODF mm	Connections types (1)	Drawing Nb	Filtering surface cm ²	Dimensions mm		
							Ø1	Ø2	L
HCYF-P14 52	1/4			1	1	70	60	64	134
HCYF-P14 52 S/MMS		1/4	6	4	2	70	60	64	124
HCYF-P14 53	3/8			1	1	70	60	64	150
HCYF-P14 53 S/MMS		3/8	10	4	2	70	60	64	124

(1) Chapter "Connection features and drawings" (refer to chapter 114 of CARLY technical catalogue).

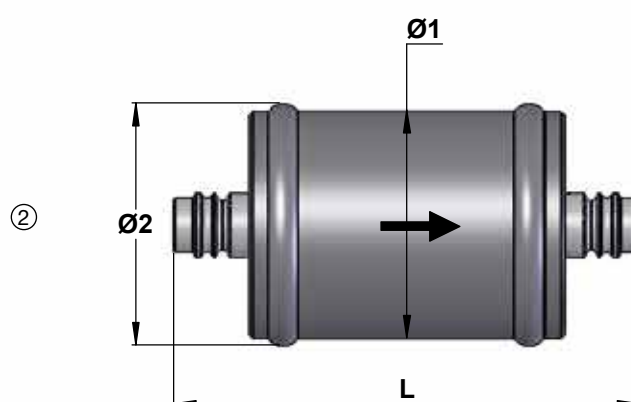
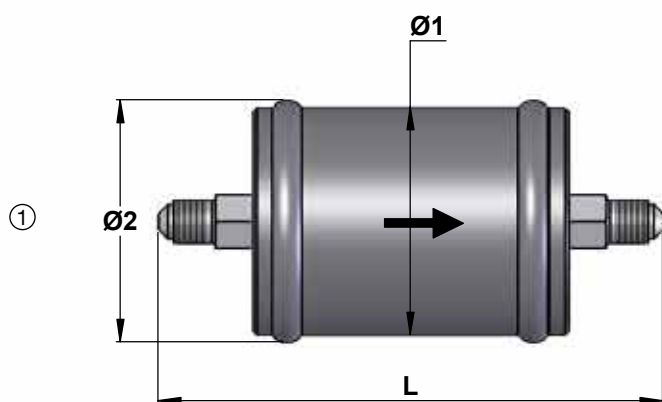

CARLY references	Volume V L	Maximal working pressure PS bar	Working pressure (1)		Maximal working temperature TS maxi °C	Minimal working temperature TS mini °C	Working temperature (1)		CE Category (2)
			PS BT bar	TS BT °C					
HCYF-P14 52	0,11	140	15	120	-40	-30	Art4§3		
HCYF-P14 52 S/MMS	0,11	140	15	120	-40	-30	Art4§3		
HCYF-P14 53	0,11	140	15	120	-40	-30	Art4§3		
HCYF-P14 53 S/MMS	0,11	140	15	120	-40	-30	Art4§3		

(1) The working pressure is limited to the PS BT value when working temperature is lower than or equal to TS BT value.

(2) Classification by volume, according to PED 2014/68/EU (refer to chapter 0 of CARLY technical catalogue).



Oil filters

→ HCYF-P14 / 140 bar (2030 psig)

■ Weights and packaging

CARLY references	Unit weight kg		Packaging number of pieces
	With packaging	Without packaging	
HCYF-P14 52	1,20	1,07	1
HCYF-P14 52 S/MMS	1,20	1,07	1
HCYF-P14 53	1,20	1,07	1
HCYF-P14 53 S/MMS	1,20	1,07	1