



Replaceable core filter drier shells (liquid line)

→ BCY-P6 / PS 64 bar (928 psig)

■ Applications

- Refrigerant filtering and drying and acid neutralization for refrigerating and air conditioning installation liquid lines, running in high working pressures.
- Replaceable core filter drier shells allow the replacement of the filter drier's active parts only.

Shell reference	Core reference (size)
BDCY	CCY 42
BCY / BCY-HP	CCY 48 / PLATINIUM 48
BCY-P6 / BCY-P14	PLATINIUM 48 / CCY 48
BBCY	CCY 100 / PLATINIUM 100



64 bar

CO₂ SUBCRITICAL

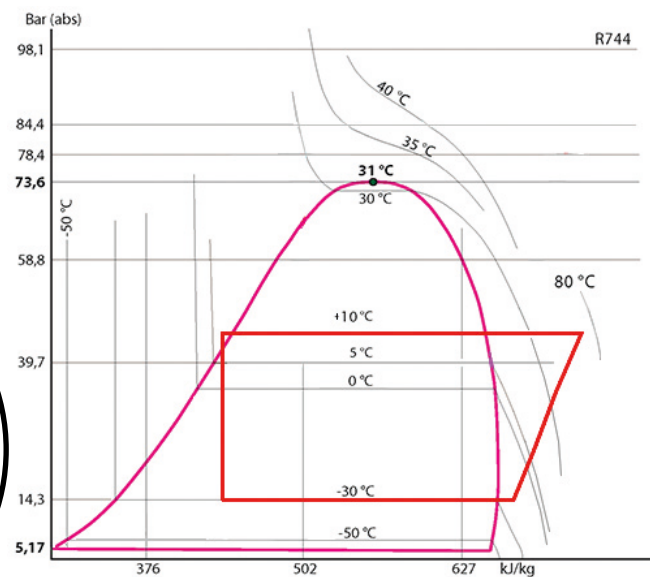

■ Functional features

- Products are compatible with HFC and CO₂, as well as with their associated oils and additives. Products are designed for use of non-hazardous refrigerants from group 2 of PED 2014/68/EU.
- Product classification in CE categories is performed using the PED 2014/68/EU table, corresponding to a volume-based selection.
- Filtering at outlet preventing the propagation within the circuit of particles bigger than 150 microns, with a very low pressure drop.
- 1/4" NPT taper tapping and its plug on end plate, allowing the installation of a pressure tap or a feeding valve.
- End plate perfectly tight thanks to its circular rim and its gasket compatible with all HFC and CO₂.

■ Possible customization on demand :

- PS 64 bar for BCY-P6 of 3 and 4 cores.

■ CARLY advantages

- Maximum working pressure : up to 64 bar for the BCY-P6 of 1 and 2 cores, with CO₂ in subcritical compression systems.
- Individual core holders treated against corrosion by zinc coating, with a reduced course for easy core replacement; therefore, replacement time is extremely reduced, limiting the time the drying cores and the inner part of the circuit are exposed to the atmosphere.
- Hermetically sealed external body made of steel to which an impregnation varnish and paint are applied to ensure a high resistance to corrosion ; this varnish ensures the internal anti-corrosion protection of the shell when it is opened for the initial set-up or during the replacement of the drying cores.
- Core holder design ensures automatic and immediate centring of the filter drier shells.
- No flow area restriction outside the filter drier shells thanks to an appropriate filtering system.



CTCY-FR – 6.17-4 / 06-2018

Replaceable core filter drier shells (liquid line)

→ BCY-P6 / PS 64 bar (928 psig)

■ Warning

Before selecting or installing any component, please refer to the chapter 0 of CARLY technical catalogue - **WARNING**.

■ General assembly precautions

The installation of a component in a refrigeration system by a skilled professional, requires some precautions:

- Some are specific to each component,
- Other are general to all CARLY components,

and in this case, they are specified in the **RECOMMENDATIONS SPECIFIC** part defined hereafter ;

they are presented in the chapter 115 – **GENERAL ASSEMBLY PRECAUTIONS**.

■ Specific recommendations to replaceable core filter drier shells BCY-P6

- Filter drier shells are to be mounted on the liquid line between the receiver and the expansion element.
- The refrigerant flow direction, indicated by an arrow on the filter drier shells' tags, should be complied with.
- Assembly can be performed in any position, but not vertically with the outlet connection oriented downwards.
- During filter drier shells assembly, provide for sufficient course to allow core replacement (refer to sizes L2 in the technical features table).
- The connection to the installation, by soldering or welding, of the filter shell, must be done only after removing the closing flange, its gasket and the internal core holders.
- The blue gasket of the closing flange must be lubricated before its installation, with refrigerating oil compatible with the oil of the installation.
- We recommend to clean and to protect the connections of the filter drier shell with appropriate products in order to ensure a good resistance to corrosion of the affected areas.
- Be careful to properly select the solenoid valves located downstream of the filter drier shells; their oversizing could cause liquid hammer phenomena hindering the filter drier shells' proper mechanical behaviour; protection of the regulation elements upstream of the evaporator should be performed with FILTRY dirt filters (refer to chapter 11 of CARLY technical catalogue); these liquid hammer phenomena can originate from other sources, in long-piping installations.
- Never install filter drier shells in an area of the circuit that can be isolated.
- Never trap refrigerant in its liquid state (between a check valve and a solenoid valve, for instance).
- The filter drier shells' efficiency and the refrigerant's moisture content should be checked using liquid sight glasses.
- Make sure that the piping can support without deformation the weight of the filter drier shell ; otherwise, provide for a clamp of the filter drier shell with a clamp on a stable part of the installation.
- In case of replacement of removable elements of filter drier shells BCY-P6 (flange, screw, gasket), it is mandatory to use only identical components, suggested by CARLY in the list of spare parts at the end of this chapter.

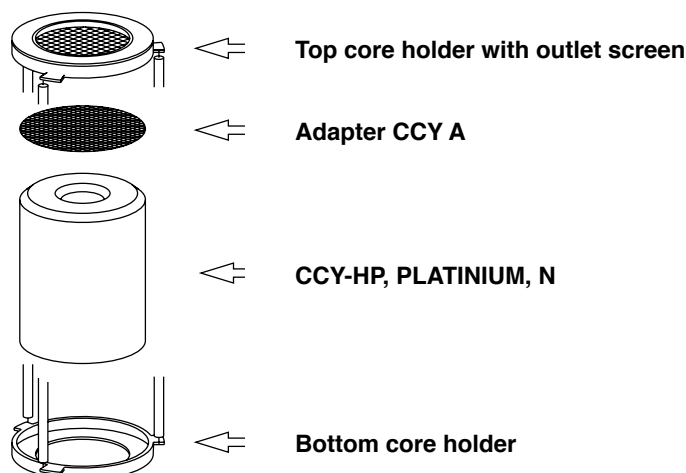



Replaceable core filter drier shells (liquid line)

→ **BCY-P6 / PS 64 bar (928 psig)**

■ Special precautions for components used with CO₂ in subcritical and transcritical systems

- The maximal working pressure and the power variations of the installation must be taken into account as of its design, in order to select all the components consequently.
- The pressure of the circuit during the stop phases must also be taken into account, because it can be very high, due to the pressure equalization according to the ambient temperature; several solutions exist to limit and control this pressure when the installation is stopped.
 - Design of the installation allowing to resist to this pressure.
 - Implementation of a « buffer » volume of storage or expansion (receiver).
 - Installation of a secondary circuit with valve or solenoid valve, allowing the fluid transfer to the coldest point, or the less high in pressure of the installation.
 - Implementation of a small separate refrigeration unit, to maintain the liquid temperature at a pressure lower than the maximal working pressure ; it is so far the most effective technical solution, but with a major drawback, which is the power failure (safety unit to be considered, or backup power supply).
- The hot gas defrost, frequently used with CO₂ for low temperatures applications, generates also high pressures (to take in consideration)
- The implementation on the liquid line of a filter drier shell **BCY-P6** equipped with drying cores **CCY 48 HP** or **PLATINIUM 48**, is highly recommended. Serious problems can occur in the presence of moisture, such as expansion valve blocking and formation of dry ice and even carbonic acid. To avoid this, it is imperative to limit the circuit openings in order to avoid air introduction, causing the condensation in the pipes, and to proceed to a high evacuation of the installation, before any commissioning or restarting.
- For an operation with CO₂ at low temperature, provide thermal insulation on the components which can be covered by frost.
- There is no incompatibility between CO₂ and the main metallic materials commonly used in refrigeration systems (steel, copper, brass...)
- On the other hand, there is a real compatibility issue between CO₂ and polymers. For example, swelling phenomena and internal explosion of the seal are possible. Carly filter drier shells BCY-P6 do not have polymer gaskets directly in contact with CO₂.



Replaceable core filter drier shells (liquid line)

→ BCY-P6 / PS 64 bar (928 psig)

■ Core replacement procedure (CCY 48, PLATINIUM 48)

- 1 • Isolate the **BCY-P6** filter drier shell.
- 2 • Purge the installation up to atmospheric pressure (shell should be empty of refrigerants)
- 3 • Remove the end plate.
- 4 • Remove the core holders one after the other.
- 5 • Remove the used cores.
- 6 • Clean very carefully the core holders, the adapter (**CCY A 48**) and the inner part of the shell case.
- 7 • Replace systematically the blue gasket on the end plate, and lubricate it before its installation with refrigerating oil compatible with the oil of the installation.

⚠ Attention : this gasket is specific for this type of shell and it is not included with CCY 48 HP and PLATINIUM 48 cores; it will have to be supplied separately, its reference is indicated in the spare parts list, in the end of this chapter; check the core holder and core end gaskets.
- 8 • Remove the core from its can and put it on the core holder, separating by traction the two flanges that hold the core holder (sketch 1)
- 9 • Repeat the operation for each core holder.
- 10 • Quickly install the core holders with their core in the shell, complying with their mounting order: the first one holds the filter elements and the last one is the one equipped with the compression spring (sketch 2)
- 11 • Reinstall the closing flange making sure that the compression spring is correctly positioned and gradually and uniformly tighten the closing screws (refer to chapter 115 of CARLY technical catalogue – **GENERAL MOUNTING PRECAUTIONS** – Criss-cross tightening). Maximum bolt tightening torque: 30 N.m.
- 12 • Make sure that the end plate's 1/4" NPT taper tapping has been properly plugged in and sealed
- 13 • Make vacuum in the installation and check air-tightness of the whole set before putting back under pressure.

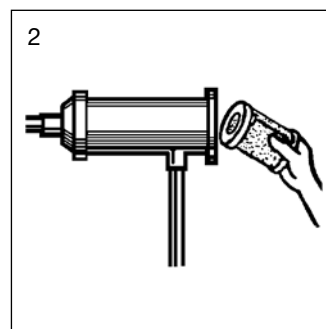
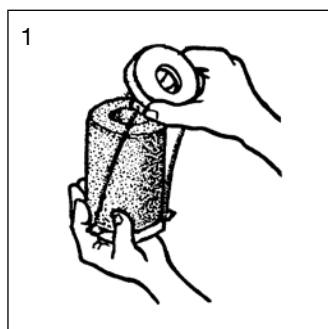

⚠ The standard gasket of the CCY (neoprene) is not compatible with CO₂. Use the reference CY 1555200.



Replaceable core filter drier shells (liquid line)

→ BCY-P6 / PS 64 bar (928 psig)

■ Selection table

CARLY references	Connections	CARLY references	Connections	Refrigerating capacity kW ⁽¹⁾					Number of cores
	To solder ODF inch		To solder ODF mm	R 134a	R410A	R404A	R507	R744 ⁽²⁾	
BCY-P6 485 S/MMS	5/8	BCY-P6 485 S/MMS	16	86,0	93,0	61,0	61,0	106,0	1
BCY-P6 487 S/MMS	7/8	BCY-P6 487 S/MMS	22	139,0	151,0	100,0	100,0	171,0	1
BCY-P6 489 S/MMS	1 1/8	BCY-P6 489 S/MMS	28	188,0	205,0	135,0	135,0	232,0	1
BCY-P6 4811 S/MMS	1 3/8	BCY-P6 4811 S/MMS	35	225,0	245,0	161,0	161,0	277,0	1
BCY-P6 4813 S	1 5/8	BCY-P6 4813 MMS	42	273,0	297,0	195,0	195,0	336,0	1
BCY-P6 4817 S/MMS	2 1/8	BCY-P6 4817 S/MMS	54	319,0	347,0	228,0	228,0	392,0	1
BCY-P6 967 S/MMS	7/8	BCY-P6 967 S/MMS	22	143,0	155,0	102,0	102,0	176,0	2
BCY-P6 969 S/MMS	1 1/8	BCY-P6 969 S/MMS	28	214,0	233,0	153,0	153,0	264,0	2
BCY-P6 9611 S/MMS	1 3/8	BCY-P6 9611 S/MMS	35	304,0	331,0	217,0	217,0	375,0	2
BCY-P6 9613 S	1 5/8	BCY-P6 9613 MMS	42	373,0	406,0	267,0	267,0	460,0	2
BCY-P6 9617 S/MMS	2 1/8	BCY-P6 9617 S/MMS	54	377,0	410,0	269,0	269,0	464,0	2

⁽¹⁾ Refrigerating capacities according to Standard ARI 710-86 for $T_o = -15\text{ °C}$, $T_k = 30\text{ °C}$ and $\Delta p = 0.07\text{ bar}$.
If different conditions, refer to correction factors in chapter 112 of CARLY technical catalogue.

⁽²⁾ Refrigerating capacities Q_n for $T_k = -10\text{ °C}$ and $T_o = -40\text{ °C}$.
If different conditions, refer to correction factors in chapter 112 of CARLY technical catalogue.

Nota: the diameter of connections must not be inferior to the diameter of the main pipe.



CTCY-FR – 6.17-4 / 06-2018

Replaceable core filter drier shells (liquid line)

→ BCY-P6 / PS 64 bar (928 psig)

■ Technical features

CARLY references	Connection types ⁽¹⁾	Filtering surface cm ²	Dimensions mm							Weight kg
			Ø1	Ø2 ⁽²⁾	Ø3	L1	L2	E1	E2	
BCY-P6 485 S/MMS	1	420	121	128	150	230	210	141,5	82,5	5,0
BCY-P6 487 S/MMS	1	420	121	128	150	240	210	151,0	92,5	5,1
BCY-P6 489 S/MMS	1	420	121	128	150	245	210	156,0	97,5	5,2
BCY-P6 4811 S/MMS	1	420	121	128	150	254	210	151,5	108,0	5,3
BCY-P6 4813 S BCY-P6 4813 MMS	1	420	121	128	150	254	210	151,0	107,0	5,4
BCY-P6 4817 S/MMS	1	420	121	128	150	267	210	164,5	124,0	5,6
BCY-P6 967 S/MMS	1	840	121	128	150	380	210	291,0	92,5	6,4
BCY-P6 969 S/MMS	1	840	121	128	150	385	210	296,0	97,5	6,5
BCY-P6 9611 S/MMS	1	840	121	128	150	394	210	292,0	108,0	6,7
BCY-P6 9613 S BCY-P6 9613 MMS	1	840	121	128	150	394	210	291,0	107,0	6,8
BCY-P6 9617 S/MMS	1	420	121	128	150	407	210	304,5	124,0	6,9

⁽¹⁾ Chapter «Connection features and drawings» (refer to chapter 114 of CARLY technical catalogue).

⁽²⁾ Including weld.

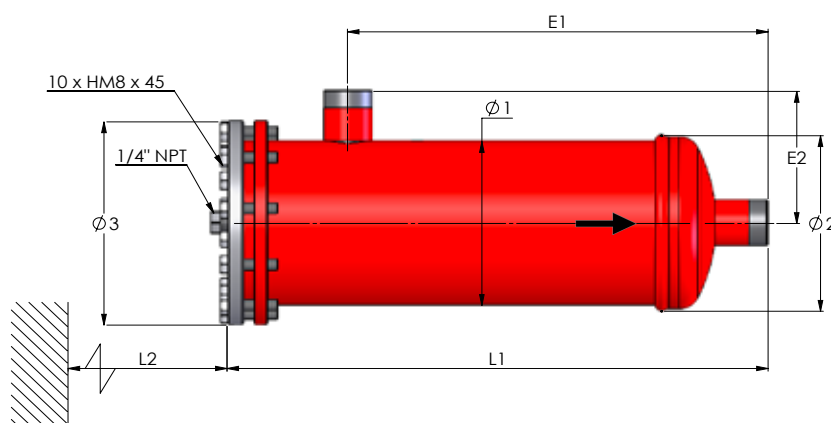

CARLY references	Volume	Maximal working pressure	Working pressure ⁽¹⁾	Maximal working temperature	Minimal working temperature	Working temperature ⁽¹⁾	CE Category ⁽²⁾
BCY-P6 485 S/MMS	1,90	64	15	120	-40	-30	I
BCY-P6 487 S/MMS	1,90	64	15	120	-40	-30	I
BCY-P6 489 S/MMS	1,90	64	15	120	-40	-30	I
BCY-P6 4811 S/MMS	1,90	64	15	120	-40	-30	I
BCY-P6 4813 S BCY-P6 4813 MMS	1,90	64	15	120	-40	-30	I
BCY-P6 4817 S/MMS	2,00	64	15	120	-40	-30	I
BCY-P6 967 S/MMS	3,30	64	15	120	-40	-30	II
BCY-P6 969 S/MMS	3,30	64	15	120	-40	-30	II
BCY-P6 9611 S/MMS	3,30	64	15	120	-40	-30	II
BCY-P6 9613 S BCY-P6 9613 MMS	3,30	64	15	120	-40	-30	II
BCY-P6 9617 S/MMS	3,40	64	15	120	-40	-30	II

⁽¹⁾ The working pressure is limited to the PS BT value when working temperature is lower than or equal to TS BT value.

⁽²⁾ Classification by volume, according to PED 97/23/EC (refer to chapter 0 of CARLY technical catalogue).



Replaceable core filter drier shells (liquid line)

→ BCY-P6 / PS 64 bar (928 psig)

■ Spare parts

Shells	CARLY References for core holders	Quantity and type of gaskets for use	
		Core holders gasket ⁽¹⁾	End plate gasket ⁽²⁾
BCY-P6 1 core	CY 37001070	1 gasket CY 15558700	1 gasket CY 1555300
BCY-P6 2 cores	CY 37001030 + CY 37001090	1 gasket CY 1555200 +1 gasket CY 15558700	

⁽¹⁾ Gasket delivered with core holders

⁽²⁾ Gasket not delivered with cores CCY 48 N, CCY 48 HP and PLATINIUM 48

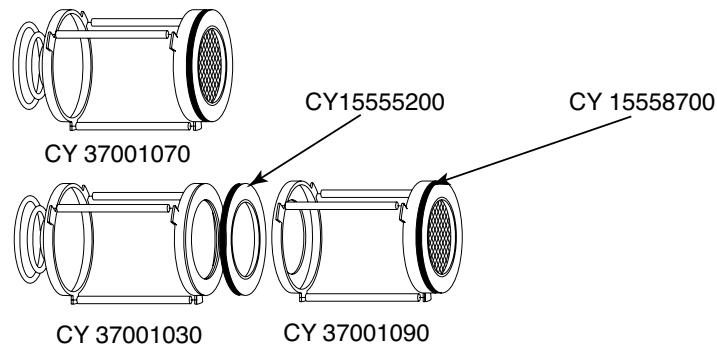

CARLY references	Part N°	Désignation	Quantity
CY 19900440	1	Set of 10 fastening screws for end plate	1
CY 10810010	2	1/4" NPT phosphate plug for end plate	1
CY 33301203	2 + 3 + 7	1/4" NPT plug + end plate + gasket	1
CY 37001030	4	Core holder (2 cores)	1
CY 37001070	4	Core holder (1 core)	1
CY 37001090	4	Core holder (2 cores)	1
CCY A 48	5	Adapter for end core holder	1
CY 1555200	6	Adhesive gasket for core holders : CY 37001030, CY 37001040 et CY 37001080	1
CY 1555303	7	End plate gasket (blue)	1

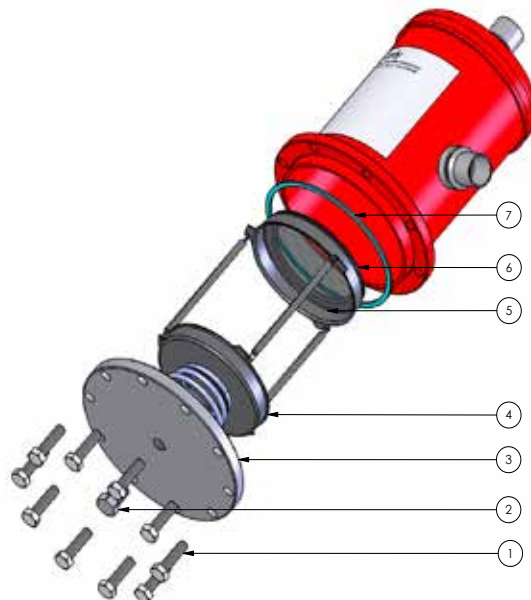



Replaceable core filter drier shells (liquid line)

→ BCY-P6 / PS 64 bar (928 psig)

■ Weights and packaging

CARLY references	Unit weight kg		Packaging number of pieces
	With packaging	Without packaging	
BCY-P6 485 S/MMS	5,22	4,97	1
BCY-P6 487 S/MMS	5,32	5,07	1
BCY-P6 489 S/MMS	5,42	5,17	1
BCY-P6 4811 S/MMS	5,47	5,22	1
BCY-P6 4813 S & MMS	5,57	5,32	1
BCY-P6 4817 S/MMS	5,82	5,57	1

CARLY references	Unit weight kg		Packaging number of pieces
	With packaging	Without packaging	
BCY-P6 967 S/MMS	6,67	6,37	1
BCY-P6 969 S/MMS	6,72	6,42	1
BCY-P6 9611 S/MMS	6,92	6,62	1
BCY-P6 9613 S & MMS	7,02	6,72	1
BCY-P6 9617 S/MMS	7,17	6,87	1