



Oil filter drier for polyol-ester oils (POE)

→ HYDROIL

01/10

■ Applications

- Continuing filtering and drying of polyol-ester oils (POE) present in the refrigerating and air conditioning installations.
- HYDROIL is a safety component for refrigerating compressors, because when the quantity of water contained in the oil is not controlled, the esters transform by hydrolysis into alcohol and fatty acids (soaps), likely to block the smallest orifices and to cause the compressor burnout.

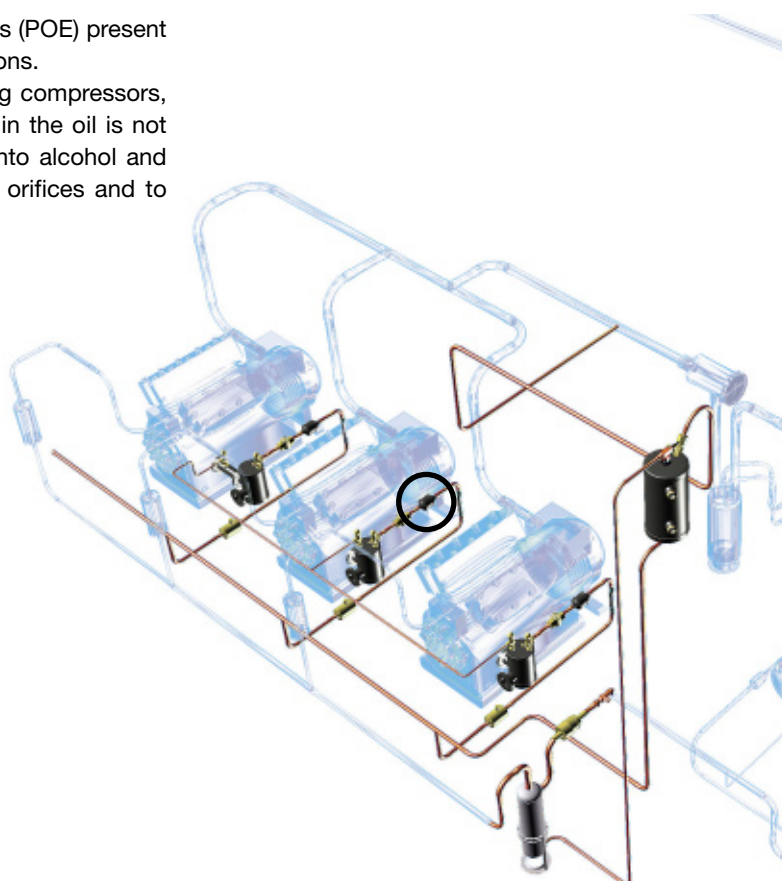

■ Functional features

- Products are compatible with HFCs, HCFCs, CFCs, as well as with their associated oils and additives. Products are designed for use of non-hazardous refrigerants from group 2 of PED 97/23/EC.
- Product classification in CE categories is performed using the PED 97/23/EC table, corresponding to a volume-based selection.
- The filtering threshold: 10 microns.
- Initial drying capacity guaranteed by a 200°C oven drying and airtight sealing.

■ CARLY advantages

- Automatic bypass of the internal filter when it is too dirty and when the pressure drop generated exceeds 0.5 bar; this particularity ensures the continuity of compressor lubrication, even if filter maintenance is late.
- A large contaminant retention capacity is ensured by an important filtering area of 175 cm² and by a volume of drying agents of 170 cm³.
- Chemical agents in the form of free grains, for increased drying performances.
- A pressure tap on the filter case makes it possible to check its good operation.
- GOST certified products.



Oil filter drier for polyol-ester oils (POE)

→ HYDROIL

01/10

■ Recommendations

- * The oil filter drier is to be mounted on the oil return line, between the oil separator and the oil level regulator, as close as possible to the latter.
- * The oil flow direction indicated by an arrow on the filter tag should be respected.
- * The clogging level of the filter must be regularly checked, making sure that the oil return is correct at compressor sumps.
- * It is highly recommended to install a HCYPV sight glass upstream of the oil filter drier, in order to visually check the presence and condition of the oil.
- * Replacement of the filter is recommended after each intervention on the oil circuit and particularly after an addition of oil.
- * The POE oils are very hydrophilous, therefore the installation of a HCYPF or HCYBF regular oil filter is not sufficient.
- * The installation of a HYDROIL oil filter drier prevents the hydrolysis reactions between moisture and oil, which generate acids and alcohols that could greatly disturb the refrigerating installation's operation.
- * Oil acidity monitoring is ensured by using TESTOIL-POE acidity tests: refer to chapter 91.
- * General assembly precautions: refer to chapter 115.

■ Technical features

CARLY references	Connections To screw SAE inch	Connections types ⁽¹⁾	Filtering surface (cm ²)	Volume of desiccation products (cm ³)	Dimensions (mm)		Net weight (kg)
					Ø	L	
HYDROIL 163	3/8	1	175	170	93	185	1,4

⁽¹⁾ Chapter "Connection features and drawings" (refer to chapter 114).

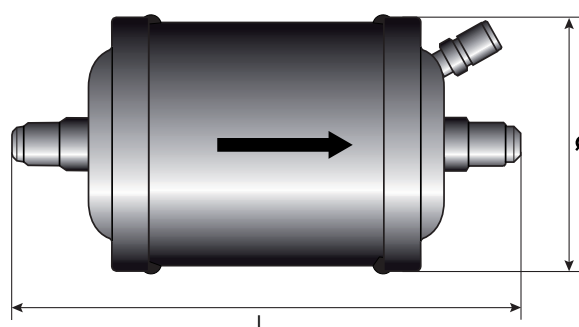

CARLY references	Volume	Maximal working pressure	Working pressure ⁽¹⁾	Maximal working temperature	Minimal working temperature	Working temperature ⁽¹⁾	CE Category ⁽²⁾
	V (L)	PS (bar)	PS BT (bar)	TS maxi (°C)	TS mini (°C)	TS BT (°C)	
HYDROIL 163	0,7	42	10	80	-40	-20	Art3§3

⁽¹⁾ The working pressure is limited to the PS BT value when working temperature is lower than or equal to TS BT value.

⁽²⁾ Classification by volume, according to PED 97/23/EC (refer to chapter 0 page 7).



Oil filter drier for polyol-ester oils (POE)

→ HYDROIL

01/10

■ Weights and packaging

CARLY references	Unit weight (kg)		Packaging unit	
	With packaging	Without packaging	standard	
HYDROIL 163	1,45	1,38	6	/